

# 75m<sup>3</sup>-STAUBGUTWAGEN | 75m<sup>3</sup> POWDER WAGON

D-Last-Allrounder | D-weight-allrounder | P81.075D



## Technische Daten | technical details

■ <b>Eigengewicht</b> Tare weight	Ca. 17,1 t Approx. 17.1 t	■ <b>Anzahl (Druck-)Kammern</b> Compartments	1 Kammer 1 chamber
■ <b>Radsatzlast</b> Axle load	22,5 t 22.5 t	■ <b>Beladeeinrichtungen</b> Loading equipment	1 Trichter/3 Konen mit konischen Fluidisierungsmatten, Austragsleitung (Edelstahl) mit Absperrklappe DN200 und Storz-Kupplung, Luftverteilerleitung (Aluminium) mit Storz-Kupplung, Entlüftungsleitung (Aluminium) mit Absperrklappe
■ <b>Abstand äußere Radsätze</b> Clearance: outer wheelsets	Ca. 15.200 mm Approx. 15,200 mm	■ <b>Entladeeinrichtungen</b> Outlet equipment	1 Hopper/3 cones with conical fluidization mats, Discharge line (stainless steel) with butterfly-valve DN200 and Storz-coupling, Air manifold line (aluminum) with Storz-coupling, Vent line (aluminum) with butterfly-valve
■ <b>Kleinster Bogenhalbmesser</b> Min. curve radius	75 m	■ <b>Trichterwandneigung</b> Inclination	3 Mannlöcher (mit 4 Schnellverschlussklemmen), DN 500 3 Manholes (with 4 quick release clamps), DN 500
■ <b>Bremse</b> Brake	Kef-GP-A, Knorr CFCB 1x Bgu	■ <b>Berechnungstemperatur</b> Design temperature	51° -40/+80°C
■ <b>Sohlenkategorie</b> Brake block category	K-Sohle K brake block		
■ <b>Werkstoff</b> Tank material	Aluminium		
■ <b>Volumen</b> Nominal volume	Ca. 75 m <sup>3</sup> Approx. 75 m <sup>3</sup>		



Die Aluminiumstaubgutwagen sind sowohl für Zement als auch für andere Produkte einsetzbar (zum Beispiel Flugasche, Weißfeintalk, Calciumcarbonat). Gern erstellen wir Ihnen eine maßgeschneiderte Lösung, die Ihren Bedürfnissen entspricht.

In addition to cement, it will be possible to use aluminum powder wagons for other products (e.g. fly ash, chalk, calcium carbonates). We would be happy to design a customized solution that meets your needs.

VTG GmbH  
Nagelsweg 34  
20097 Hamburg  
Germany

Telefon +49 40 2354-0  
info@vtg.com  
www.vtg.com

# 75m<sup>3</sup>-STAUBGUTWAGEN | 75m<sup>3</sup> POWDER WAGON

D-Last-Allrounder | D-weight-allrounder | P81.075D

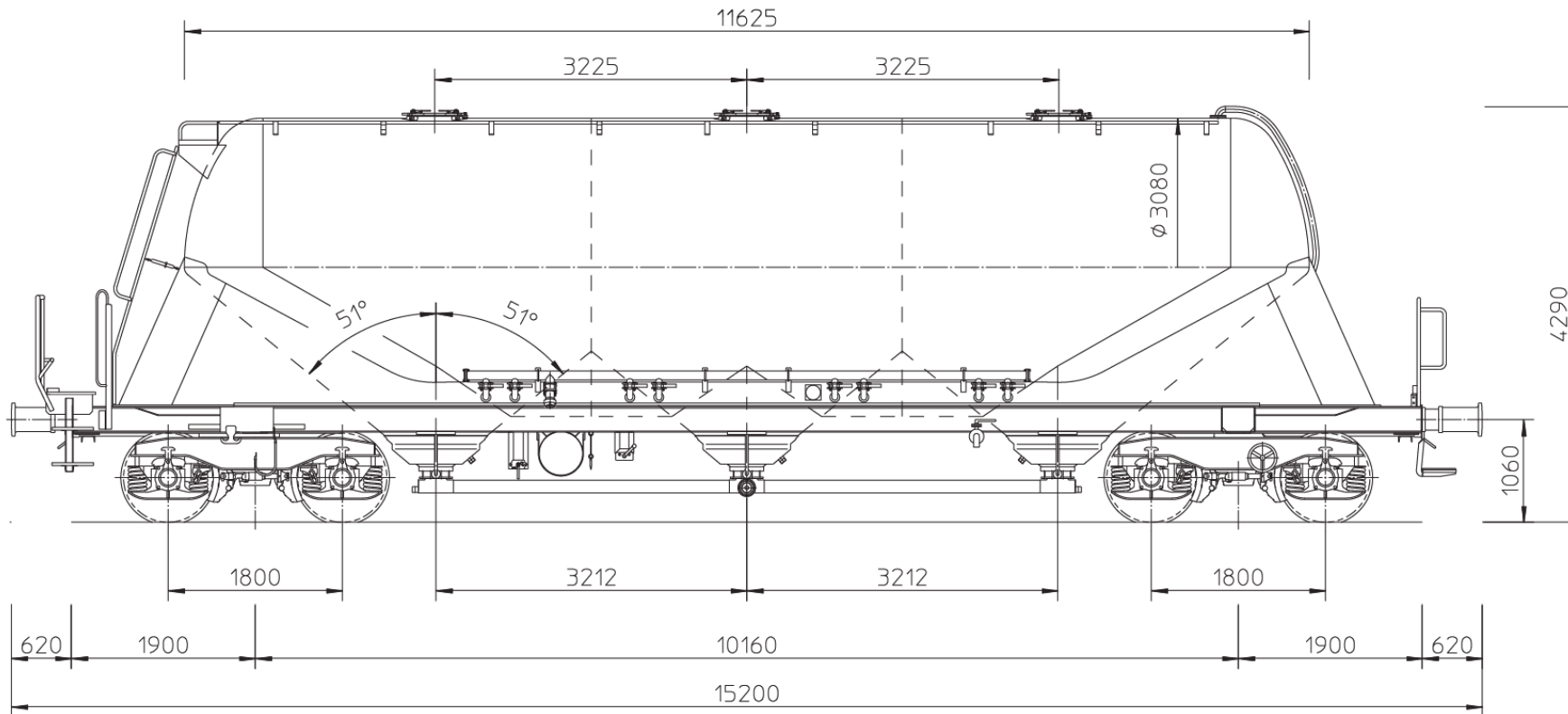

VTG GmbH  
Nagelsweg 34  
20097 Hamburg  
Germany

Telefon +49 40 2354-0  
info@vtg.com  
www.vtg.com