

PORTA-CONTENEDORES | CONTAINER CARRIER

Sgns(s) 60'E



Datos técnicos | technical details

| | | | |
|--|--|--|---|
| ■ Tara Tare weight | Aprox. 19,7 t Approx. 19.7 t | ■ Radio mín. curvatura Min. curve-radius | 120 m (para trenes completos) 120 m (in block train) |
| ■ Carga neta máxima Max. load | Aprox. 70,3 t Approx. 70.3 t | ■ Velocidad máx. Max. speed | 120 km/h |
| ■ Carga máx. bruta por eje Axle load | 22,5 t 22.5 t | ■ Longitud de carga Loading length | 18.400 mm 18,400 mm |
| ■ Diámetro de rueda Wheel diameter | 920 mm | ■ Longitud de carga en pies Loading length in feet | 60 ft |
| ■ Distancia entre topes Total length over buffers | 19.740 mm 19,740 mm | ■ Ancho de carga Loading width | 2.600 mm 2,600 mm |
| ■ Distancia entre ejes extremos Clearance: outer wheelsets | 16.000 mm 16,000 mm | ■ Altura sobre el carril, vagón vacío Loading height above top of rail, unloaded | 1.155 mm 1,155 mm |
| ■ Ancho de vía Gauge | 1.668 mm 1.435 mm 1,668 mm 1,435 mm | ■ Adecuado para ferries Ferry boat capability | 2° 30' |
| ■ Freno Brake | KE-GP-A (K) | | |
| ■ Tipo de zapata Brake block category | GG-/LL-/K/Freno de disco Gray cast iron/LL/composite brake block / disc brake | | |



El vagón más completo y flexible para el transporte intermodal, con una carga neta de aproximadamente 70.3 T. Excelente para el transporte de contenedores marítimos, cisterna y cajas móviles.

Vagón adecuado para tráfico en ancho ibérico (1.668 mm).

The most flexible „allround“ railcar for combined transportation with an ideal loading weight of 70.3 t. Excellent for maritime containers, tank containers and swap bodies.

Wagons are suitable for Iberian gauge (1,668 mm).

VTG Rail Europe GmbH
Nagelsweg 34
D-20097 Hamburg

Telefon +49 40 2354-0
info@vtg.com
www.vtg.com

PORTA-CONTENEDORES | CONTAINER CARRIER

Sgns(s) 60'E

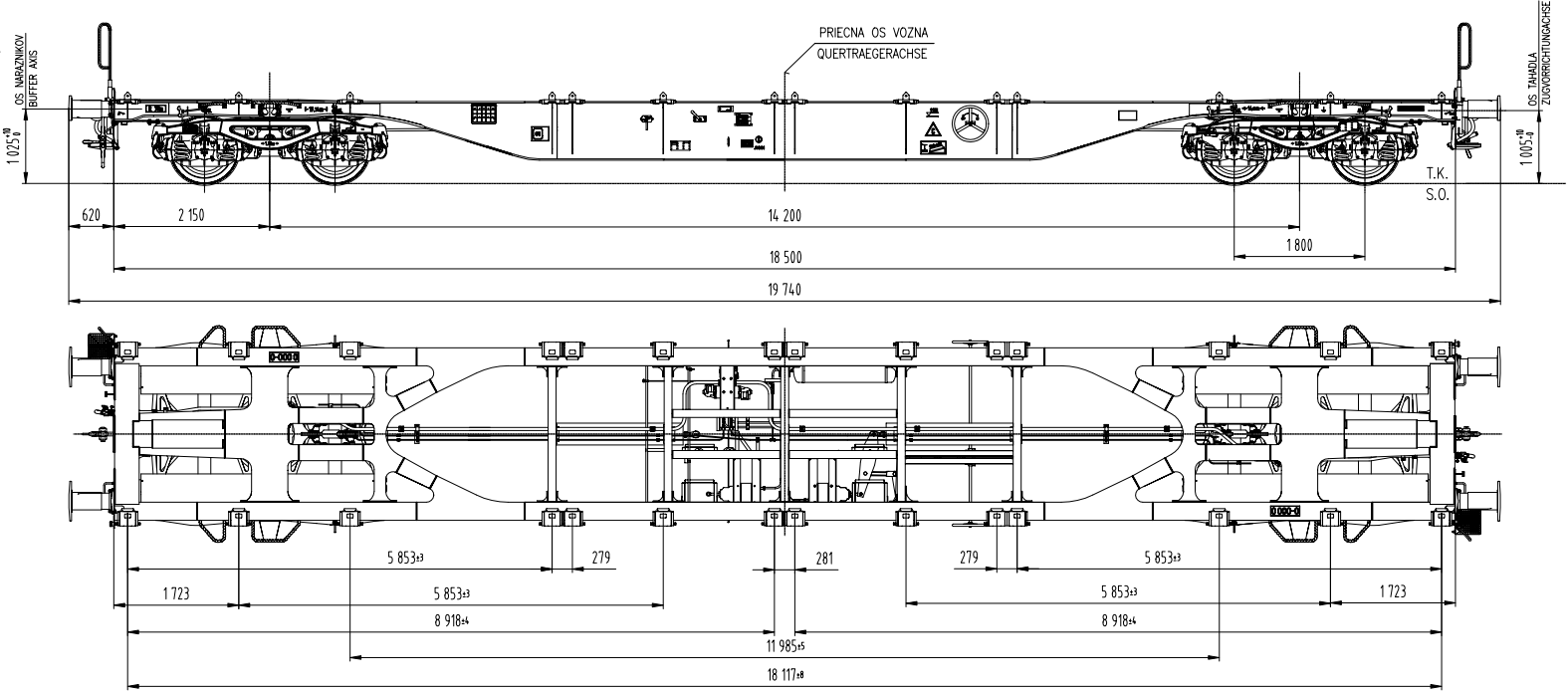

Limites de carga
Load limits

| | A | B | C | D |
|----|--------|--------|--------|--------|
| S | 44,3 t | 52,3 t | 62,3 t | 70,3 t |
| SS | 44,3 t | 52,3 t | 60,3 t | |

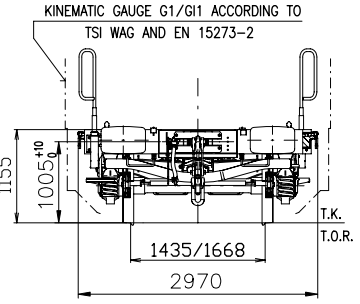

VTG Rail Europe GmbH
Nagelsweg 34
D-20097 Hamburg
Telefon +49 40 2354-0
info@vtg.com
www.vtg.com

Especificaciones sujetas a cambios / Specification subject to change